

## Passive Infrared (PIR) Fresnel Lenses

In a Fresnel lens, the outer refracting surface is compressed to a flat plane. The Fresnel lens is composed of a number of concentric grooves that refract light. A Fresnel lens can be designed to perform a number of functions, including focusing, energy collection, collimation and diffusion. These types of Fresnel lenses can be used in applications such as imaging, lighting, and passive infrared sensors.

### Features:

- Designed for wavelengths between 5 and 20 microns.
- Peak transmission between 9 to 12 microns.
- Short focal lengths for low profile sensors
- Optical surfaces are designed using Reflexite's proprietary design software.

### Applications

One of the primary uses for passive infrared (PIR) Fresnel lenses is in the security arena. In this application, a Fresnel lens array is used in conjunction with a pyroelectric detector to create a useful detection pattern. While the primary application for PIR lenses and lens arrays is the security industry, there are many other uses:

- Passive Infrared Sensors
  - Burglar alarm / Security
  - Motions activated lighting
  - Lighting control systems
  - Environmental control systems
- Non Passive Infrared Applications
  - Non contact thermometers
  - Low resolution thermal imaging
  - Protective windows for hi-res IR systems

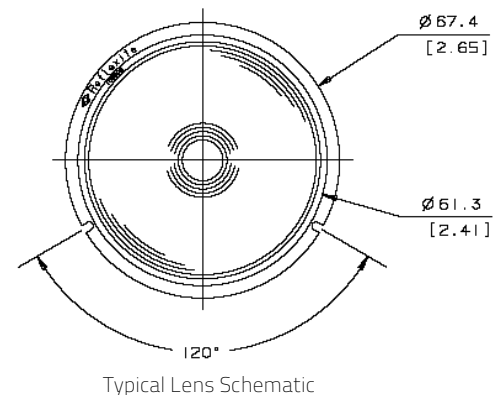

Part Number	Focal Length	Facet Spacing	Lens Aperture	Part Diameter	Part Thickness
I08809	23 mm	Variable	45 mm	67.4 mm	0.45 mm
I08831	25.4 mm	0.4 mm	48 mm	67.4 mm	0.45 mm
I08818	27 mm	0.4 mm	48 mm	67.4 mm	0.45 mm
I08834	40 mm	Variable	58 mm	67.4 mm	0.45 mm
I08800	Plano	NA	58 mm	67.4 mm	0.45 mm

Material: HDPE in Natural or White